



KAYCEE
Brand that set the standards

ROTARY CAM SWITCHES



Kaycee for Commitment...
Kaycee for Quality...



KAYCEE



With Enclosure



Front of Panel Mounting (Base Mounting)



Back of Panel Mounting

KAYCEE ROTARY CAM SWITCHES

KAYCEE Rotary Cam Switches have been engineered and designed especially to meet the requirements of latest concepts in switching technology demanding miniaturization and sophistication in control engineering. These are guaranteed for optimum performance and meet the most arduous industrial applications. Kaycee Rotary Cam Switches are hand-operated, assembled on packet principle giving choice of multi-position and multi-pole circuits.

Switches for Motor Control application covers a wide range of applications such as switching, controlling and starting of 3 phase AC squirrel cage induction motors.

Kaycee Rotary Cam switches are manufactured in the following range :

10A/440V AC, 50 Hz at 0.8 Power Factor or 6A/250VDC. (Thermal Rating)

12A/380V AC, 50 Hz at 0.8 Power Factor.

25A/250V AC or 10A/440V AC, 50 Hz at 0.8 Power Factor or 25A/250VDC. (Thermal Rating)

Motor Control Switches suitable for squirrel cage induction motors up to 7.5 H.P., 3 phase 415 VAC, 50Hz. system.

CONSTRUCTION

Kaycee Rotary Cam Switches are assembled on packet principle. Packets are manufactured from selected insulating material which can withstand mechanical and electrical stresses and have excellent electrical properties. Each packet house two independent sets of double break type silver tipped butt contacts which ensures effective making and breaking, giving long and trouble-free service. Various Cams are used depending upon the contact sequence for making and breaking, which is achieved by operating the handle.

SWITCHING ANGLE

The switches are manufactured to suit switching angles like 30°, 45°, 60° and 90° depending on the number of ways/positions, in case of stayput switches.

However, the switching angle is restricted to 30° in case of switches having spring return arrangement.

MOUNTING

As a standard, switches are suitable for flush at the back of panel (panel mounting). However, base mounting switches can be supplied on request.

ENCLOSURE

Kaycee Rotary Cam Switches are supplied in open execution. However, 25A switches and Motor Control Switches having disc built up to 4 discs can be supplied in sheet steel enclosures.

SPECIFICATIONS

Kaycee Rotary Cam Switches comply with relevant clauses of IS 4064/1978. Part-I

Kaycee 10A Rotary Cam Switches comply with relevant clauses of IS 6875/1973.

Switches of 6 A & 25 A for DC application tested at VJTI, Bombay for Rated Making and Breaking Capacity and Load Operation Test as per DC-11 Utilisation Category of IS:6875.

Kaycee Motor Control Switches meet the requirements of Utilisation category AC 3 as per IS 4064/1978. Part-II.

TEMPERATURE

The switches are recommended for use up to 55° C ambient temperature.

HIGH VOLTAGE

All switches withstand a test of 2.5 KV for one minute between phase and earth and between terminals when the switch is off.

LIFE

The mechanical life of 10A and 12A switches is virtually long, i.e. over million operations. Electrical life depends upon the application.

The mechanical life of 25A and Motor Control switches is over 1.2 million operations and the electrical life depends upon the frequency and load conditions.

OPTIONAL ACCESSORIES

A wide range of optional accessories is available.

These include:

Handles

Indicating plates

Centre Key Locks (available for only 25A switches)

Cubicle door interlock - lockable/non-lockable type (available for only 25A switches)

SPECIAL FEATURES

Switches for custom-built switching to control complex circuits are supplied against specific requirements.

Switches with spring return arrangement can be supplied against specific requirements. In case of 10A & 12A switches, spring return arrangement can be provided either on one side/both sides of center position or with the combination of stayput and spring return positions. In case of 25A switches spring return arrangement can be provided either on both sides of center or a combination of stayput and spring return positions.

(For details please refer page No. 12).

Switches with make before break contacts supplied against specific requirements.

GUARANTEE

Kaycee Rotary Cam Switches are guaranteed for one year from the date of purchase against manufacturing defects and/or faulty workmanship. This guarantee is restricted only to the repair or replacement of defective switches and not for misused and/or damaged switches.

DRAWINGS

1. Switching Angles - Please refer Pg. No. 12
2. Typical Schematics Diagram - Please refer Pg. No. 12
3. Mounting Details
 - a. 10A and 12A - Please refer Pg. No. 12 & 13
 - b. 25A and Motor Control Switches - Please refer Pg. No. 12 & 13
4. Dimensional Drawings:
 - a. Dimensional drawings of 10A and 12A Cam switches with escutcheon plate - Please refer Pg. No. 13
 - b. Dimensional drawing of 25A Cam switches with escutcheon plate with Wing type knob - Please refer Pg. No. 14
 - c. Dimensional drawing of 25A Cam switches with escutcheon plate with Ball type handle - Please refer Pg. No. 13
 - d. Dimensional drawing of 25A Cam switches with escutcheon plate with Pistol Grip Handle - Please refer Pg. No. 13
5. Dimensional drawing for 25A Cam switches/Motor Control switches with enclosure - Please refer Pg. No. 15
6. Dimensional drawing for 25A Cam switches with Centre Key Lock assembly with 'Tee' type handle - Please refer Pg. No. 14
7. Dimensional drawing for 25A Cam switches with Centre Key Lock assembly with Lever type handle - Please refer Pg. No. 14
8. Dimensional drawing of 25A Cam switches with cubicle door interlock.
 - a. Non-lockable type - Please refer Pg. No. 15
 - b. Lockable type - Please refer Pg. No. 15

CODING SYSTEM

Kaycee Rotary Cam Switches are identified by a coding system. This consists of index letters and figures grouped in sequence to indicate the salient features of the switch.

- A. First group of numerical indicates number of discs in the switch assembly.
- B. Next letter indicates the rating of the switch.
 - S - 10A/440V AC.
 - T - 12A/380V AC.
 - V - 25A/250V AC or 10A/440V AC.
 - M - Motor Control Switch suitable for squirrel cage induction Motor upto 7.5 H.P. 3 Ø, 415V AC.

	<u>Rated Thermal Current</u>	<u>Rated Insulation Voltage</u>
TD -	6 A	250 VDC
MD -	25 A	250 VDC

- C. Next group of numerical indicates the number of poles in the switch.
- D. Next group of numerical indicates the angle of throw.
 - 3 - 30° 6 - 60°
 - 4 - 45° 9 - 90°
- E. Next group of letters indicate the switching sequence.

(1) ROTARY CAM SWITCHES

- O - ON OFF BO - 2 WAY WITH OFF
- B - 2 WAY NO OFF C - 3 WAY NO OFF

and so on as indicated in the standard switches table.

(2) MOTOR CONTROL SWITCHES

- K - REVERSING WITH OFF
- SD - STAR/DELTA STARTING WITH OFF
- PC - TWO SPEED POLE CHANGING
- C - SYSTEMS SELECTOR
- F. Letter X after above group of letters indicates Base mounting switch while absence of X indicates panel mounting switch.
- G. Special Codes:
 - AP - Ammeter Selector Switch
 - VP - Voltmeter Selector Switch
 - MB - Make before Break contacts
 - RM - Spring return mechanism (Revertible Mechanism)
 - E - Switches with enclosure
- H. Group of letters written after stroke indicates the accessories, fitted with the switch.
 - P - Pistol Grip Handle
 - W - Wing type knob
 - B - Ball type handle
 - LG - Centre key lock with Lever type handle
 - TG - Centre key lock with 'Tee' type handle
 - LSH - Cubicle door interlock-nonlockable type with Lever type handle
 - LHR - Cubicle door interlock-lockable type with Lever type handle

EXAMPLE

2V23BO/RM/W

Explanation :

- 2 - No. of discs
- V - Rating of 25A/250V AC
- 2 - No. of poles
- 3 - 30° angle of throw
- BO - 2 way with off
- RM - Spring return mechanism (Revertible Mechanism)
- W - Wing type knob

ELECTRICAL RATING : Rated Thermal Current : 6ADC. Rated Insulation Voltage: 250 VDC.

Mechanical Life : Upto 5 Million cycles of operations.

DC Breaking capacity : For 25,000 operations, ratings are given in the table below :

Voltage	No. of contacts in series	Resistive	Inductive 10 M.Sec	Inductive 20 M.Sec	Inductive 40 M.Sec
50	1	6*	5	3.75	1.5
	2	-	-	5.00	3.5
	3	-	-	-	5.00
110	1	0.75	0.6	0.37	0.25
	2	5.00	3.75	2.5	1.25
	3	-	6.00	5.00	2.5
	4	-	-	-	5.00
220	1	0.25	0.12	0.07	0.05
	2	1.25	0.5	0.25	0.12
	3	5.00	2.5	1.0	0.25
	4	-	-	-	-
	5	-	-	-	-
	6	-	-	-	3.0

*Tested at VJTI, Bombay for 25,000 operations.

ELECTRICAL RATING : Rated Thermal Current : 25ADC. Rated Insulation Voltage: 250 VDC.

Mechanical Life : Upto 5 Million cycles of operations.

DC Breaking capacity : For 25,000 operations, ratings are given in the table below :

Voltage	No. of contacts in series	Resistive	Inductive 10 M.Sec	Inductive 20 M.Sec	Inductive 40 M.Sec
50	1	20	20	15*	6
	2	-	-	20*	14
	3	-	-	-	20
110	1	3	2.5	1.5*	1
	2	20	15	10*	5
	3	-	20	20*	10
	4	-	-	-	20
220	1	1	0.5	0.3	0.2
	2	5	2	1*	0.5
	3	20	10	4*	1
	4	-	-	-	-
	5	-	-	-	-
	6	-	-	-	12

*Tested at VJTI, Bombay for 25,000 operations.

STANDARD CAM SWITCHES

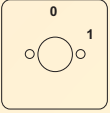
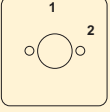
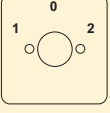
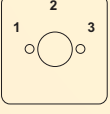
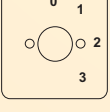
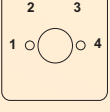
CODE	DESCRIPTION	POLES	10 Amps.	6 Amps.	12 Amps.		25 Amps.			
			Type for AC	Type for DC	'Y' Dimn.	Type For AC	'Y' Dimn.	Type for AC	Type for DC	'Y' Dimn.
O	ON OFF 2 Position 60° 	1	1S16O	1TD 16O	33	1T16O	33	1V16O/W	1MD 16O/W	19
		2	1S26O	1TD 26O	33	1T26O	33	1V26O/W	1MD 26O/W	19
		3	2S36O	2TD 36O	43	2T36O	43	2V36O/W	2MD 36O/W	32
		4	2S46O	2TD 46O	43	2T46O	43	2V46O/W	2MD 46O/W	32
B	2 Way NO OFF 2 Position 60° 	1	1S16B	1TD 16B	33	1T16B	33	1V16B/W	1MD 16B/W	19
		2	2S26B	2TD 26B	43	2T26B	43	2V26B/W	2MD 26B/W	32
		3	3S36B	3TD 36B	52	3T36B	52	3V36B/W	3MD 36B/W	45
		4	4S46B	4TD 46B	62	4T46B	62	4V46B/W	4MD 46B/W	58
BO	2 Way with OFF 3 Position 60° 	1	1S16BO	1TD 16BO	33	1T16BO	33	1V16BO/W	1MD 16BO/W	19
		2	2S26BO	2TD 26BO	43	2T26BO	43	2V26BO/W	2MD 26BO/W	32
		3	3S36BO	3TD 36BO	52	3T36BO	52	3V36BO/W	3MD 36BO/W	45
		4	4S46BO	4TD 46BO	62	4T46BO	62	4V46BO/W	4MD 46BO/W	58
C	3 Way NO OFF 3 Position 60° 	1	2S16C	2TD 16C	43	2T16C	43	2V16C/W	2MD 16C/W	32
		2	3S26C	3TD 26C	52	3T26C	52	3V26C/W	3MD 26C/W	45
		3	5S36C	5TD 36C	71	5T36C	71	5V36C/W	5MD 36C/W	71
		4	6S46C	6TD 46C	81	6T46C	81	6V46C/W	6MD 46C/W	84
CO	3 Way with OFF 4 Position 45° 	1	2S14CO	2TD 14CO	43	2T14CO	43	2V14CO/W	2MD 14CO/W	32
		2	3S24CO	3TD 24CO	52	3T24CO	52	3V24CO/W	3MD 24CO/W	45
		3	5S34CO	5TD 34CO	71	5T34CO	71	5V34CO/W	5MD 34CO/W	71
		4	6S44CO	6TD 44CO	81	6T44CO	81	6V44CO/W	6MD 44CO/W	84
D	4 Way NO OFF 4 Position 60° 	1	2S16D	2TD 16D	43	2T16D	43	2V16D/W	2MD 16D/W	32
		2	4S26D	4TD 26D	62	4T26D	62	4V26D/W	4MD 26D/W	58
		3	6S36D	6TD 36D	81	6T36D	81	6V36D/W	6MD 36D/W	84
		4	8S46D	8TD 46D	100	8T46D	100	8V46D/W	8MD 46D/W	110

STANDARD CAM SWITCHES

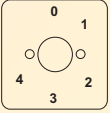
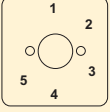
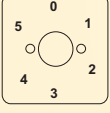
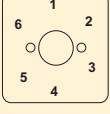
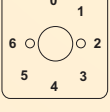
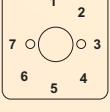
CODE	DESCRIPTION	POLES	10 Amps.	6 Amps.	12 Amps.		25 Amps.			
			Type for AC	Type for DC	'Y' Dimn.	Type for AC	'Y' Dimn.	Type for AC	Type for DC	'Y' Dimn.
DO	4 Way with OFF 5 Position 60° 	1	3S16DO	3TD 16DO	52	3T16DO	52	3V16DOW	3MD 16DOW	45
		2	5S26DO	5TD 26DO	71	5T26DO	71	5V26DOW	5MD 26DOW	71
		3	8S36DO	8TD 36DO	100	8T36DO	100	8V36DOW	8MD 36DOW	110
		4	10S46DO	10TD 46DO	119	10T46DO	119	10V46DOW	10MD 46DOW	136
E	5 Way NO OFF 5 Position 60° 	1	3S16E	3TD 16E	52	3T16E	52	3V16E/W	3MD 16E/W	45
		2	5S26E	5TD 26E	71	5T26E	71	5V26E/W	5MD 26E/W	71
		3	8S36E	8TD 36E	100	8T36E	100	8V36E/W	8MD 36E/W	110
		4	10S46E	10TD 46E	119	10T46E	119	10V46E/W	10MD 46E/W	136
EO	5 Way with OFF 6 Position 60° 	1	3S16EO	3TD 16EO	52	3T6EO	52	3V16EOW	3MD 16EOW	45
		2	6S26EO	6TD 26EO	81	6T26EO	81	5V26EOW	6MD 26EOW	71
		3	9S36EO	9TD 36EO	109	9T36EO	109	8V36EOW	9MD 36EOW	110
		4	12S46EO	12TD 46EO	138	12T46EO	138	12V46EOW	12MD 46EOW	162
F	6 Way NO OFF 6 Position 60° 	1	3S16F	3TD 16F	52	3T16F	52	3V16F/W	3MD 16F/W	45
		2	6S26F	6TD 26F	81	6T26F	81	6V26F/W	6MD 26F/W	84
		3	9S36F	9TD 36F	109	9T36F	109	9V36F/W	9MD 36F/W	123
		4	12S46F	12TD 46F	138	12T46F	138	12V46F/W	12MD 46F/W	162
FO	6 Way with OFF 7 Position 45° 	1	4S14FO	4TD 14FO	62	4T14FO	62	4V14FOW	4MD 14FOW	58
		2	7S24FO	7TD 24FO	90	7T24FO	90	7V24FOW	7MD 24FOW	97
		3	11S34FO	11TD 34FO	128	11T34FO	128	11V34FOW	11MD 34FOW	149
G	7 Way NO OFF 7 Position 45° 	1	4S14G	4TD 14G	62	4T14G	62	4V14G/W	4MD 14G/W	58
		2	7S24G	7TD 24G	90	7T24G	90	7V24G/W	7MD 24G/W	97
		3	11S34G	11TD 34G	128	11T34G	128	11V34G/W	11MD 34G/W	149

STANDARD CAM SWITCHES

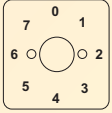
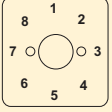
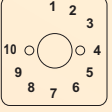
CODE	DESCRIPTION	POLES	10 Amps.	6 Amps.	12 Amps.		25 Amps.			
			Type for AC	Type for DC	'Y' Dimn.	Type for AC	'Y' Dimn.	Type for AC	Type for DC	'Y' Dimn.
GO	7 Way with OFF	1	4S14GO	4TD 14GO	62	4T14GO	62	4V14GO/W	4MD 14GO/W	58
	8 Position 45°	2	8S24GO	8TD 24GO	100	8T24GO	100	8V24GO/W	8MD 24GO/W	110
		3	12S34GO	12TD 34GO	138	12T34GO	138	12V34GO/W	12MD 34GO/W	162
H	8 Way NO OFF	1	4S14H	4TD 14H	62	4T14H	62	4V14H/W	4MD 14H/W	58
	8 Position 45°	2	8S24H	8TD 24H	100	8T24H	100	8V24H/W	8MD 24H/W	110
		3	12S34H	12TD 34H	138	12T34H	138	12V34H/W	12MD 34H/W	162
HO	8 Way with OFF	1	5S13HO	5TD 13HO	71	5T13HO	71	5V13HO/W	5MD 13HO/W	71
	9 Position 30°	2	10S23HO	10TD 23HO	119	10T23HO	119	10V23HO/W	10MD 23HO/W	136
J	9 Way NO OFF	1	5S13J	5TD 13J	71	5T13J	71	5V13J/W	5MD 13J/W	71
	9 Position 30°	2	9S23J	9TD 23J	109	9T23J	109	9V23J/W	9MD 23J/W	123
JO	9 Way with OFF	1	5S13JO	5TD 13JO	71	5T13JO	71	5V13JO/W	5MD 13JO/W	71
	10 Position 30°	2	10S23JO	10TD 23JO	119	10T23JO	119	10V23JO/W	10MD 23JO/W	136
K	10 Way NO OFF	1	5S13K	5TD 13K	71	5T13K	71	5V13K/W	5MD 13K/W	71
	10 Position 30°	2	10S23K	10TD 23K	119	10T23K	119	10V23K/W	10MD 23K/W	136
										

STANDARD CAM SWITCHES

CODE	DESCRIPTION	POLES	10 Amps.	6 Amps.	12 Amps.		25 Amps.			
			Type for AC	Type for DC	'Y' Dimn.	Type for AC	'Y' Dimn.	Type for AC	Type for DC	'Y' Dimn.
KO	10 Way with OFF	1	6S13KO	6TD 13KO	81	6T13KO	81	6V13KO/W	6MD 13KO/W	84
	11 Position 30°	2	11S23KO	11TD 23KO	128	11T23KO	128	11V23KOW	11MD 23KOW	149
L	11 Way NO OFF	1	6S13L	6TD 13L	81	6T13L	81	6V13L/W	6MD 13L/W	84
	11 Position 30°	2	11S23L	11TD 23L	128	11T23L	128	11V23L/W	11MD 23L/W	149
LO	11 Way with OFF	1	6S13LO	6TD 13LO	81	6T13LO	81	6V13LOW	6MD 13LOW	84
	12 Position 30°	2	12S23LO	12TD 23LO	138	12T23LO	138	12V23LOW	12MD 23LOW	162
M	12 Way NO OFF	1	6S13M	6TD 13M	81	6T13M	81	6V13M/W	6MD 13M/W	84
	12 Position 30°	2	12S23M	12TD 23M	138	12T23M	138	12V23M/W	12MD 23M/W	162
RO	REVERSING with OFF	2	2S26RO	2TD 26RO	42	2T26RO	42			
	3 Position 60°	3	3S36RO	3TD 36RO	52	3T36RO	52			

INSTRUMENTS SWITCHES VOLTMETER SELECTOR

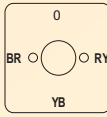
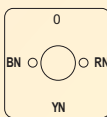
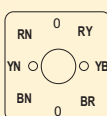
Code	Description	10 Amps		12 Amps	
		Type	'Y' Dimn.	Type	'Y' Dimn.
VP	 Voltage between phases with OFF 4 Position 90°	3S39VP	52	3T39VP	52
VN	 Voltage between phases and Neutral with OFF 4 Position 90°	3S49VN	52	3T49VN	52
VPN	 Voltage between phases and each Phase and Neutral with OFF 8 Position 45°	4S44VPN	62	4T44VPN	62

AMMETER SELECTOR

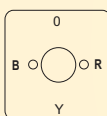
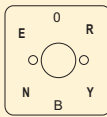
AP	 Current in each phase with OFF 4 Position 90°	4S39AP	62	4T39AP	62
APN	 Current in each phase neutral and leakage with OFF 3 Position 60°	6S56APN	81	6T56APN	81

MOTOR CONTROL SWITCHES

	Application	Type	Indicating Plate Marking	No. of Position	Angle of throw	No. Of Packets	'Y' Dimn.
1.	ON OFF	2M6OB	0-1	2	60°	2	32
2.	Reversing	3M6KB	1-0-1	3	60°	3	45
3.	Star / Delta	4M6SDB	0-●-↻-	3	60°	4	58
4.	Two Speed Pole Changing						
	a. Separate Windings	3M6PCB	0-1-2	3	60°	3	45
	b. Dahalander Windings	4M6PCB	0-1-2	3	60°	4	58
	c. Reversing	7M4PCKB	2-1-0-1-2	5	45°	7	97
5.	System Selector	3M6CB	1-0-2	3	60°	3	45

Motor Control Switches having disc built-up upto 4 disc can be supplied in sheet steel enclosure.

10-12 Amp.

MOUNTING DETAILS (EXPLODED VIEW)

PANEL MOUNTING

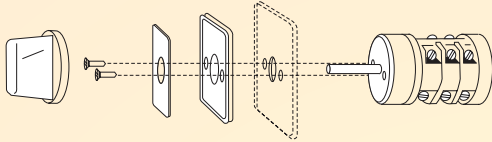

BASE MOUNTING

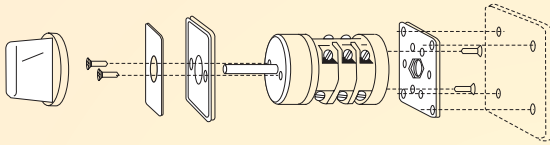

SWITCHING ANGLES OF SPRING RETURN

Angle of Throw Stayput Position 90°

Spring Return Position 30°

10-12-25 A SWITCHES

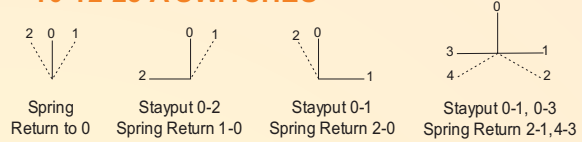

10-12 A SWITCHES

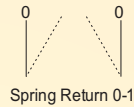

Note : 10-12 Amp cam switches with spring return can be offered up to 3 packets.

25 Amp



1) Handle

The switch is supplied with a choice of two handles – Wing type and Ball type – (as illustrated), which has a predetermined position with respect to the spindle. Fix the handle by means of a screw provided with the switch.

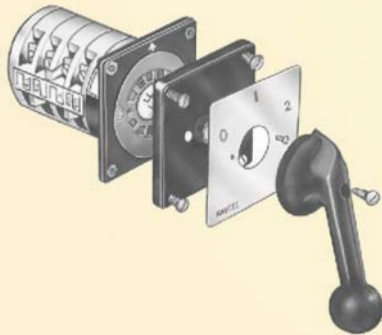

2) Switch Mounting with indicating Plate

The switch is provided with – 4-M4 C'Sunk Head Screws – Escutcheon Plate – Indicating Plate – 2-6BA Screws Handle. Mount the switch from the back of the panel, and escutcheon plate from the front of the panel with 4-M4 C'sunk head screws. Fix the indicating plate over the escutcheon plate with 2-6BA screws and replace the handle as shown.

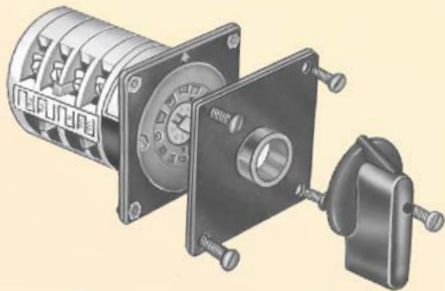

3) Switch Mounting without Indicating Plate

The switch is provided with – 4-M4 C'sunk Head Screws Bearing Plate Handle. Mount the switch and bearing plate from the back of the panel with 4-M4 C'sunk head screws and replace the handle from the front as shown.

10-12-25 Amp

SWITCHING ANGLES

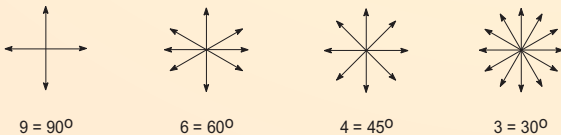

TYPICAL SCHEMATIC DIAGRAMS (SINGLE POLE)

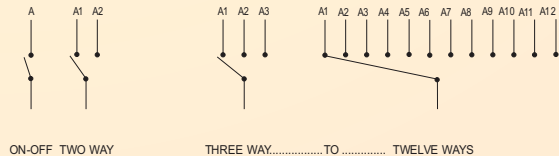

DIMENSION

(All in mm.)

10 Amp. Cam Switch

No. OF DISCS	DIM "Y"
1	33
2	43
3	52
4	62
5	71
6	81
7	90
8	100
9	109
10	119
11	128
12	138

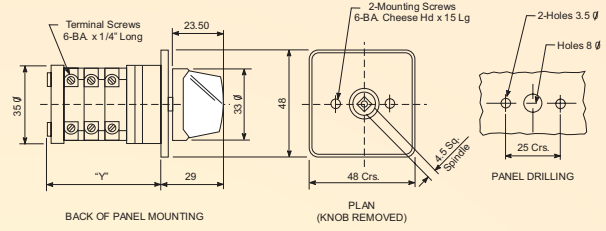

No. OF DISCS	DIM "Y"
1	36
2	46
3	55
4	65
5	74
6	84
7	93
8	103
9	112
10	122
11	131
12	141

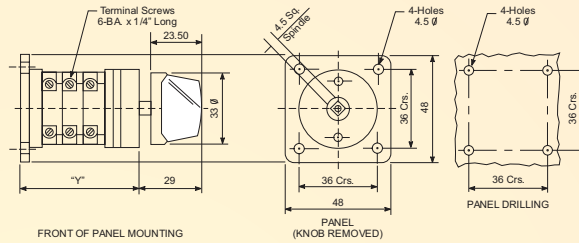

GENERAL TOLERANCES	
Full Figure	± 1
Up to 1st Decimal	± 0.5
Up to 2nd Decimal	± 0.25

Dr. No. CS-C 11037/2

25 Amp. Cam Switch With Escutcheon Plate With Ball Type Handle

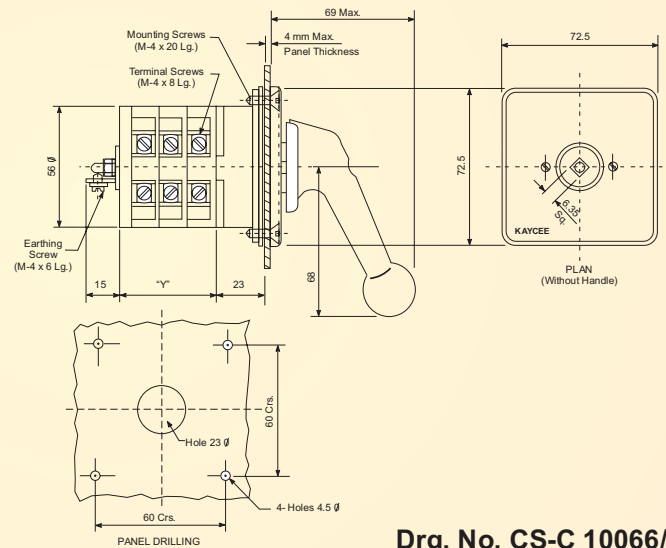

No. OF DISCS	2	3	4	5	6	7	8	ADD FOR EACH DISC
DIMENSION "Y"	32	45	58	71	84	97	110	13

GENERAL TOLERANCES	
Full Figure	± 1
Up to 1st Decimal	± 0.5
Up to 2nd Decimal	± 0.25

Dr. No. CS-C 10066/1

25 Amp. Cam Switch With Escutcheon Plate With Pistol Grip Type Handle

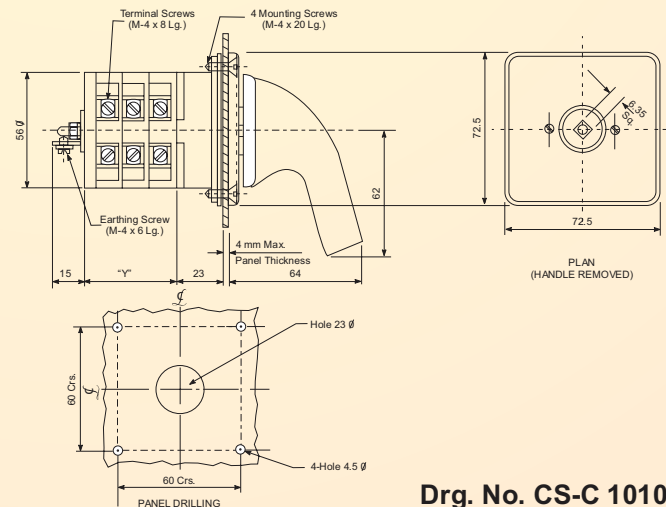

No. OF DISCS	2	3	4	5	6	7	8	ADD FOR EACH DISC
DIMENSION "Y"	32	45	58	71	84	97	110	13

GENERAL TOLERANCES	
Full Figure	± 1
Up to 1st Decimal	± 0.5
Up to 2nd Decimal	± 0.25

Dr. No. CS-C 10105

DIMENSION

(All in min.)

25 Amp. Cam Switch With Escutcheon Plate With Wing Type Knob

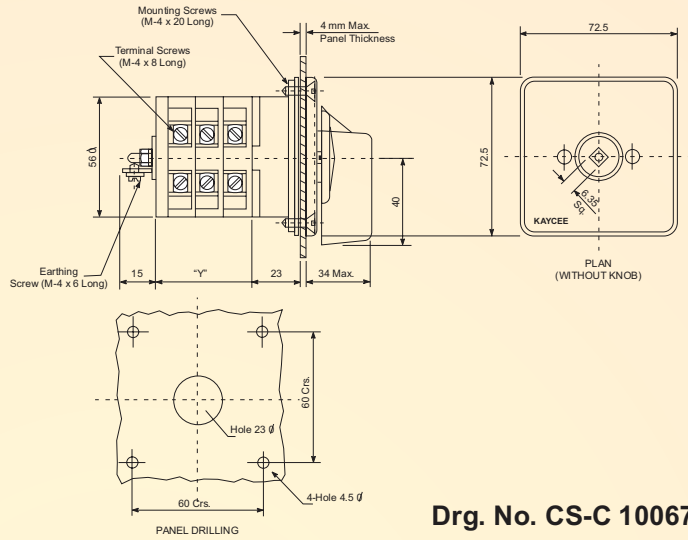

Dr. No. CS-C 10067/1

No. OF DISCS	2	3	4	5	6	7	8	ADD FOR EACH DISC
DIMENSION "Y"	32	45	58	71	84	97	110	13

GENERAL TOLERANCES	
Full Figure	± 1
Up to 1st Decimal	± 0.5
Up to 2nd Decimal	± 0.25

25 Amp. Cam Switch Centre Key Lock Assembly With Lever Type Handle ('LG' Type)

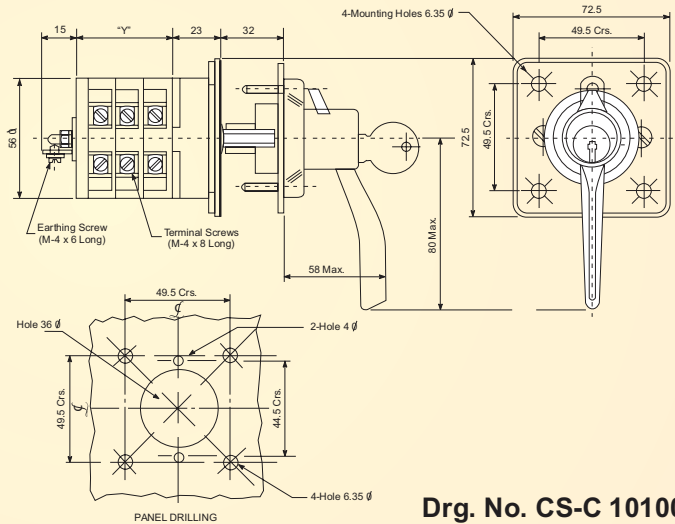

Dr. No. CS-C 10100

No. OF DISCS	2	3	4	5	6	7	8	ADD FOR EACH DISC
DIMENSION "Y"	32	45	58	71	84	97	110	13

GENERAL TOLERANCES	
Full Figure	± 1
Up to 1st Decimal	± 0.5
Up to 2nd Decimal	± 0.25

25 Amp. Cam Switch With Centre Key Lock Assembly With 'Tee' Type Handle

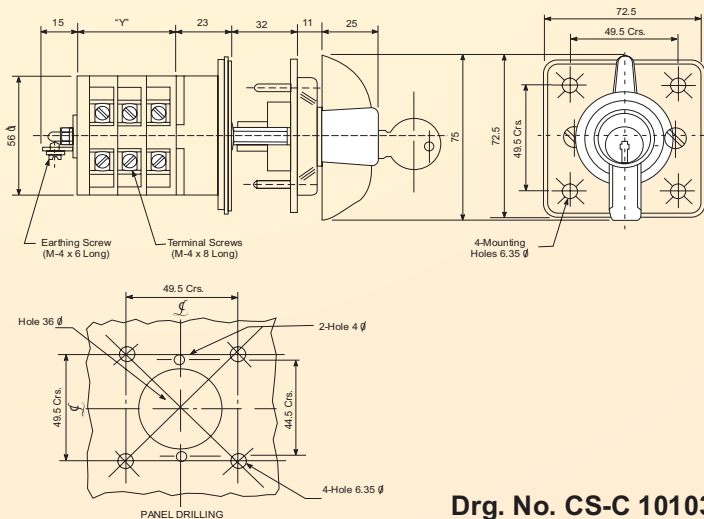

Dr. No. CS-C 10103

No. OF DISCS	2	3	4	5	6	7	8	ADD FOR EACH DISC
DIMENSION "Y"	32	45	58	71	84	97	110	13

GENERAL TOLERANCES	
Full Figure	± 1
Up to 1st Decimal	± 0.5
Up to 2nd Decimal	± 0.25

DIMENSION

(All in mm.)

25 Amp. Cam Switch With Cubicle Door Interlock With Lever Type Handle (Lockable 'LHR' Type)

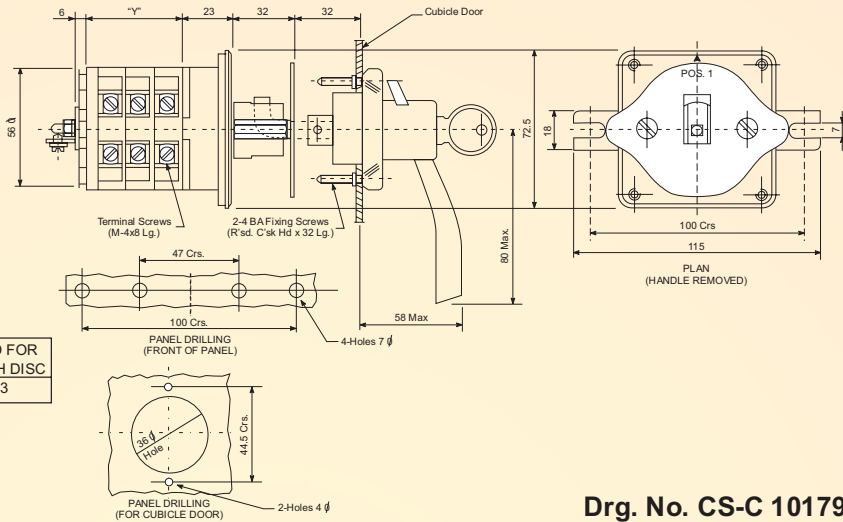

No. OF DISCS	2	3	4	5	6	7	8	ADD FOR EACH DISC
DIMENSION "Y"	32	45	58	71	84	97	110	13

GENERAL TOLERANCES	
Full Figure	± 1
Up to 1st Decimal	± 0.5
Up to 2nd Decimal	± 0.25

Drg. No. CS-C 10179

25 Amp. Cam Switch With Cubicle Door Interlock With Lever Type Handle (Non-Lockable 'LHR' Type)

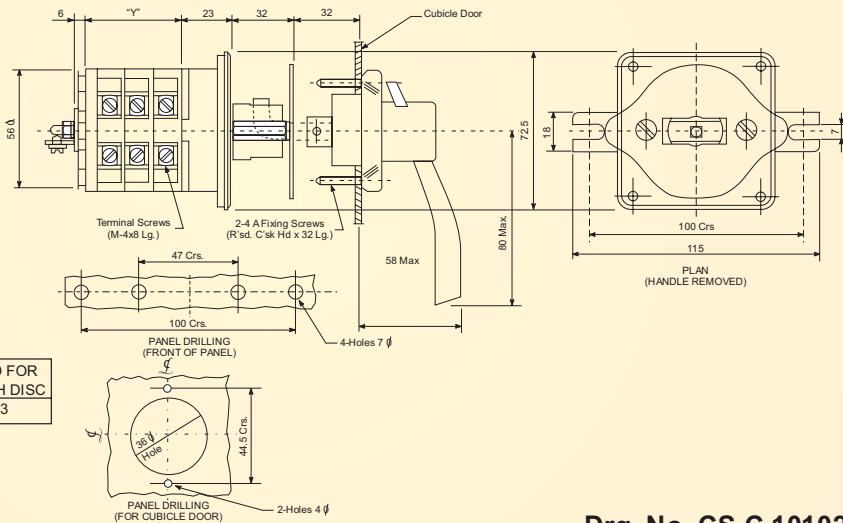

No. OF DISCS	2	3	4	5	6	7	8	ADD FOR EACH DISC
DIMENSION "Y"	32	45	58	71	84	97	110	13

GENERAL TOLERANCES	
Full Figure	± 1
Up to 1st Decimal	± 0.5
Up to 2nd Decimal	± 0.25

Drg. No. CS-C 10102

25 Amp. Cam Switch With Enclosure (Only up to 4 Disc switch)

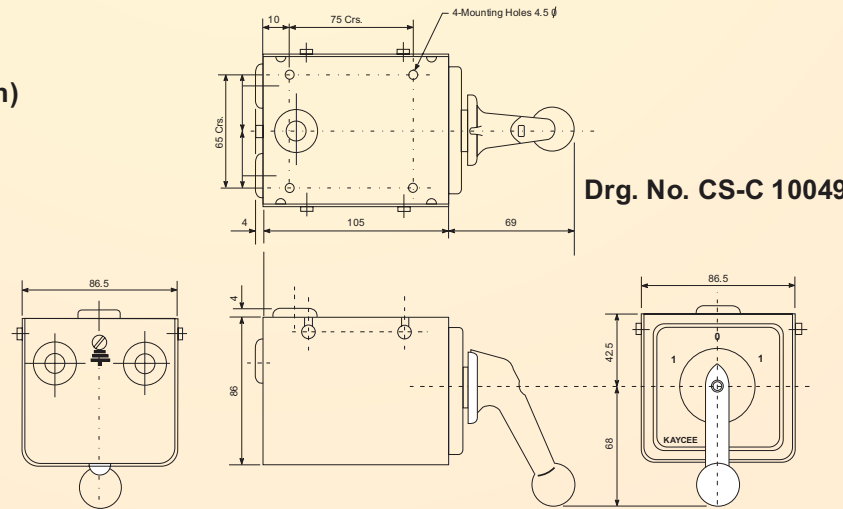

GENERAL TOLERANCES	
Full Figure	± 1
Up to 1st Decimal	± 0.5
Up to 2nd Decimal	± 0.25

Drg. No. CS-C 10049

KAYCEE OTHER PRODUCTS

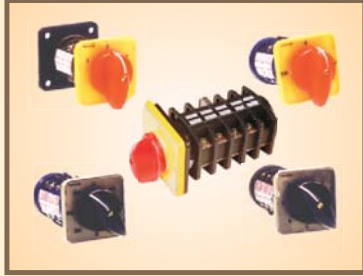

Manufactured by :
KAYCEE INDUSTRIES LIMITED

32, Ramjibhai Kamani Road, Ballard Estate,
Mumbai - 400 001.
Tel. : +91 (22) 2261 3521 / 22 / 23
Fax : +91 (22) 2261 6106
E-mail : kayceeindltd@vsnl.com
Website : www.kayceeindustries.com

Branch Offices :
Delhi : 093120 04687
Kolkata : 093392 00968
Indore : 093007 51464
Bangalore : 093428 53324
Chennai : 093812 01556

